

Quadron™ UV Series

SUSTAINABLE UV DISINFECTION WITH MINIMUM FOOTPRINT



WEDECO
a xylem brand

Exceeding Reliability, Reducing Footprint

Xylem's Wedeco Quadron is the treatment experts' choice when looking for a proven UV disinfection solution with minimum footprint. Its compact shape due to powerful medium pressure UV lamps and unique hydraulic design features allow a flexible installation for all site conditions. The disinfection performance is guaranteed by the most complete validation according to UVDGM* and DVGW** certification.

Most Complete Proof of Performance

The Quadron series is designed for maximum effectiveness against waterborne pathogens with special attention to the effects of low UV wavelengths (< 240 nm).

Quadron systems are certified according to DVGW, and have been uniquely tested and validated with two different quartz sleeves according to the US EPA's UV Disinfection Guidance Manual (UVDGM 2006), resulting in two validated performance approaches:

- For applications where certainty of dose delivery is paramount by using quartz sleeves that block low UV wavelengths (as required for DVGW certification today). This is considered as a future option for the UVDGM.
- For maximum possible treated flow by using sleeves that allow all wavelengths to pass.

No Assumptions, Just Reality

Each Quadron's PLC is programmed with validation/certification equations. This takes sensor readings of flow, UV transmittance and individual lamp intensities to calculate the real time dose. No assumptions are made regarding process parameters, ensuring confidence in the applied disinfection. In addition the sophisticated control algorithm allows the system to always operate at maximum efficiency.

Easy Fit to Local Conditions

The compact in-line design, in conjunction with the patented OptiCone™ flow diverter, guarantees excellent flow conditions in every installation situation. This provides an easy fit into existing pipe work or confined conditions. Even with a close coupled 90 degree bend, the OptiCone still ensures balanced flows across the UV lamps.

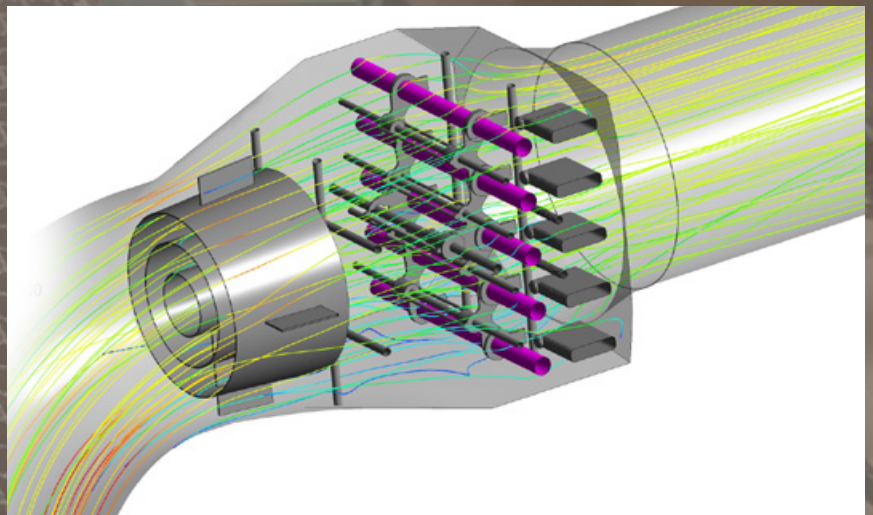

Efficient Operation Through Superior Design

Easy Fit to Local Conditions

Fieldbus network control is used to transfer all sensor signals to the control cabinet. This considerably reduces the wiring work and makes the installation less susceptible to electrical interference signals.

All fittings are arranged along one side to allow close installation with the system's back to surrounding structures.

Reduced Maintenance Costs

UV lamps and sensors are accessible from one side and can be replaced quickly and easily without emptying the reactor.

A service hatch enables work to be carried out inside the system without dismantling the system from the pipe work.

The automatic wiping system keeps the sleeves clean, eliminating manual cleaning effort and enabling all UV light to enter the water for peak efficiency. The wiping system is chemical free with no need to store and refill chemicals.



Quadron 1200

Reduced Operational Costs

The electronic ballasts are optimized to the Multiray™ medium pressure UV lamps ensuring the highest level of operational safety and long lamp life.



The UV power of the lamps is continuously adjustable from 30-100% with a guaranteed

lamp life of more than 8,000 hours. The combination of longer lamp life and minimized power consumption results in reduced operating costs.

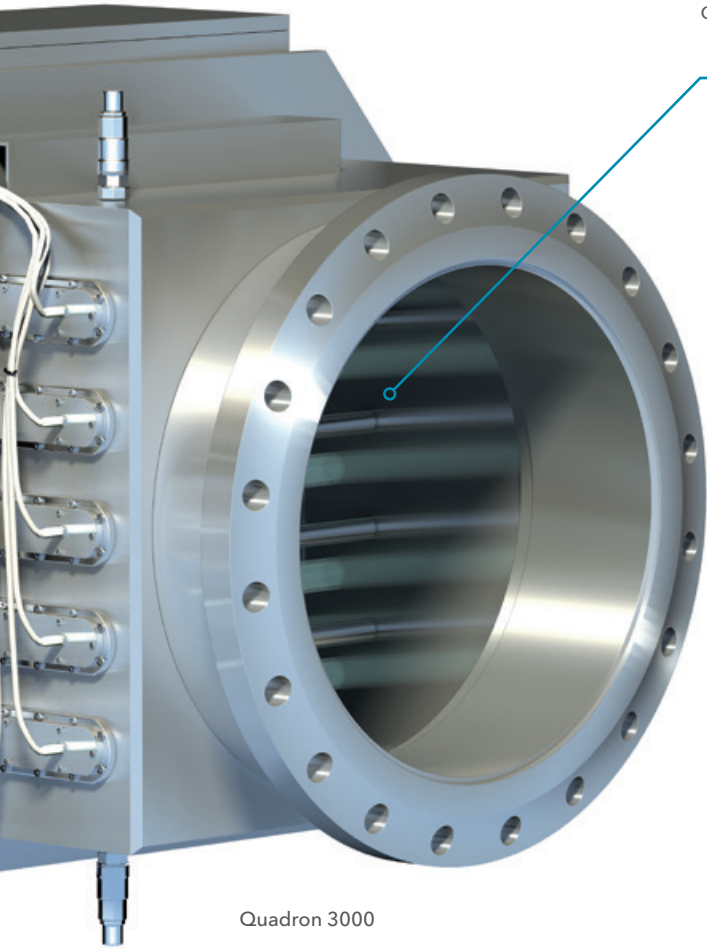

Quadron 3000

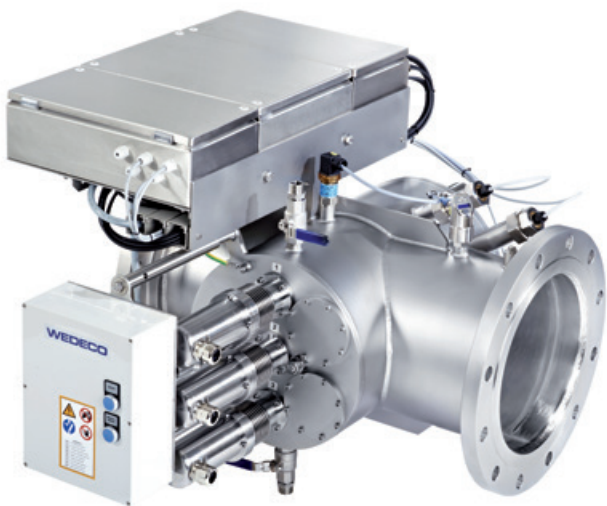

Quadron 600

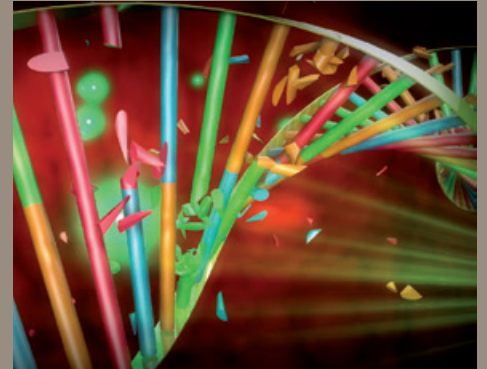

Water disinfection through the use of UV technology is the process of inactivating microorganisms due to photo oxidation of the organism's DNA. The UV radiation alters the DNA in the cells of the microorganisms and stops their ability to reproduce. More than 99.99% of all pathogens can be rendered harmless in a fraction of a second.

There are certain aspects that need to be considered specifically when designing a medium pressure UV system for drinking water works, mainly caused by the low wavelengths (below 240 nm).

Let Xylem help you determine which UV system is right for you.

Strong arguments for powerful solutions

Reliable Disinfection Performance

- Third party UVDGM validation and DVGW certification provides the highest proof of performance, required or accepted in countries all over the world.
- The Quadron's UVDGM validation allows special attention to the effects of low UV wavelengths (< 240 nm) on specific pathogens (such as Cryptosporidium) typically targeted in for municipal drinking water disinfection.
- Each medium pressure UV lamp is monitored by its own UV sensor for precise UV dose control.
- The applied UV dose is based on actual UV intensity and water conditions measured in real time, ensuring disinfection confidence at any moment.

Reduced Operational and Maintenance Costs

- The OptiCone flow diverter optimizes the water flow that maximize disinfection efficiency, resulting in optimized energy consumption. Moreover, its low head loss keeps pumping costs down.
- Wedecos's OptiDose Control, sensor-based UV dose pacing keeps the system operating at optimum efficiency for reduced energy consumption.
- The Multiray UV lamps run for more than 8,000 hours - guaranteed even under dimming mode - reducing spares and maintenance.
- The automatic, chemical-free wiping system keeps the sleeves clean, virtually eliminating manual cleaning effort and enabling all UV light to enter the water for peak efficiency.
- UV lamps and sensors are accessible from one side only without emptying the reactor. A service hatch enables work inside the system.
- Xylem's TotalCare program offers services that help identify energy saving potential for the duration of the system's service life.

Easy Installation for All Site Conditions

- Powerful medium pressure UV lamps allow for reduced lamp count and length, leading to extremely compact reactors.
- In-line design and OptiCone flow diverter ensure easy integration into pipe work regardless of the orientation (vertically / horizontally) or upstream bends.
- One-sided maintenance allows close installation to surrounding structures.
- Fieldbus technology reduces wiring work.
- Xylem's TotalCare program offers comprehensive commissioning services for a smooth installation and start-up phase.

Sustainable Solution

- Fit for the future, the Quadron is designed to meet certain proposed updates to the UVDGM, ensuring sufficient disinfection capacity without additional upgrades.
- As a purely physical disinfection solution, and 100% chemical free, UV does not carry the risk of forming harmful by-products, such as trihalomethanes (THMs) and haloacetic acids (HAAs). In addition, the Quadron's automatic wiping system works without chemical cleaning additives.
- Replacing chlorine with UV reduces handling and transportation risks of chemicals, avoiding dangers for plant operators, the environment and the public.
- UV disinfected water has a high public acceptance as it has no potential negative effects on the environment and human health. Furthermore, it helps preserve the fresh taste of water without any unnatural smells and tastes sometimes caused by chemical disinfection.

Technical Data

System	Quadron 600	Quadron 1200	Quadron 3000
UV transmittance range in % (1cm)	60-98		
Maximum flow rate (m ³ /h / MGD)	1200 / 7.5	2800 / 18	4100 / 26
DVGW	Yes		
UVDGM (2006)	Yes		

UV Lamps and Monitoring System			
Lamp technology	WEDECO Multiray medium-pressure		
Power per lamp (W)	6000		9300
Number of lamps	3	4	5
Lamp certification	3 rd party on aging		
UV intensity monitoring	Germicidal, ÖNORM compliant, one sensor per lamp		
Individual lamp monitoring	Yes		

UV Reactor			
Protection class	IP 65 / NEMA 4X		
Flow diverter	OptiCone™		
Automatic cleaning system	automatic, mechanical		
Reactor material	Stainless steel 1.4404 / 1.4435 (ASTM 316L)		
Flange sizes	DN 300 / ANSI 12"	DN 450 / ANSI 18"	DN 600 / ANSI 24"
Vessel dimensions A x B x C x D (mm / inch) acc. to drawing	755 x 1100 x 880 x 770 / 29.7 x 43.3 x 34.6 x 30.3	1050 x 1100 x 880 x 950 / 41.3 x 43.3 x 34.6 x 37.4	1100 x 1500 x 1200 x 1200 / 43.3 x 59.1 x 47.2 x 47.2
Maximum operating pressure (bar/PSI)	10 / 145		

UV System Control Cabinet			
Ballast type	Electronic, high-efficiency, variable output (30 to 100% power)		
Controller	PLC		
Materials of construction	Painted sheet steel or Stainless steel		
Dimensions W x H x D (mm / inch) approx.	1400 x 2200 x 600 / 55.1 x 86.6 x 23.6		1800 x 2160 x 600 / 70.9 x 85 x 23.6
Electrical standards	CE, UL, cUL		
Common outputs	System Status, Lamp Status, Alarm Messages, Process Values		
Scada communication	Yes		
Protection class	IP 54 / Type 12		
Supply voltage	CE / UL / cUL: 400 / 480V +-10%; 50/60Hz. TN- net. L1, L2, L3, PE / WYE		
Power consumption (kW) approx.	19.5	26	48

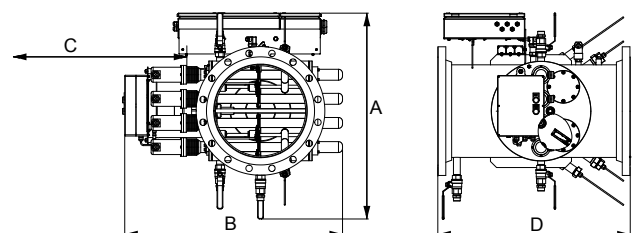

Xylem |'zīləm|

- 1) The tissue in plants that brings water upward from the roots;
- 2) a leading global water technology company.

We're 12,700 people unified in a common purpose: creating innovative solutions to meet our world's water needs. Developing new technologies that will improve the way water is used, conserved, and re-used in the future is central to our work. We move, treat, analyze, and return water to the environment, and we help people use water efficiently, in their homes, buildings, factories and farms. In more than 150 countries, we have strong, long-standing relationships with customers who know us for our powerful combination of leading product brands and applications expertise, backed by a legacy of innovation.

For more information on how Xylem can help you, go to www.xylem.com



BAO BINH TECHNOLOGY CO., LTD

Address: 816/20 Truong Sa, Ward 14, District 3, HCMC, Vietnam.

Tel. +84 28 38420440 Fax. +84 28 38420460

www.bbtec.com.vn



Xylem Services GmbH
Boschstr. 4 - 14
32051 Herford, Germany
Phone +49 5221 930 0
Fax +49 5221 930 222
www.xylem.com

